

Equipment

HATCH

Babcock-Davis' Equipment Roof Hatch is engineered to accommodate extra large equipment access through roofs. With options like curb mounting and varied curb heights Babcock-Davis is sure to meet your equipment servicing needs.

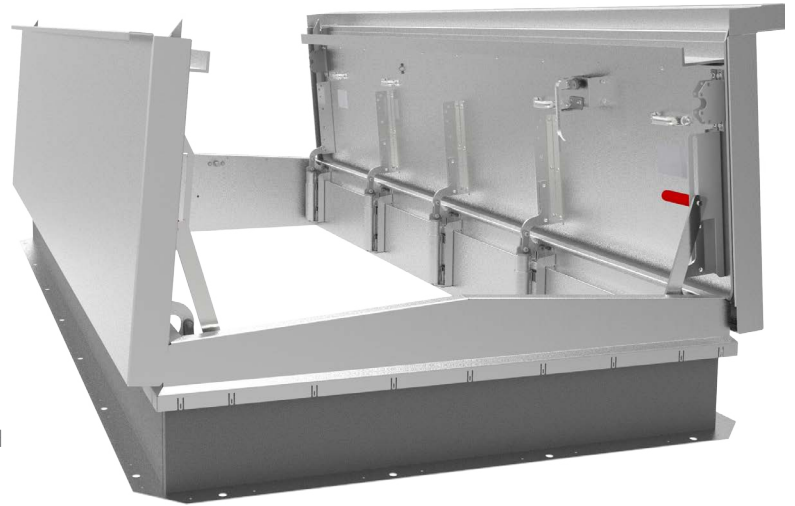

FEATURES

LARGEST CLEAR OPENING Industry's largest clear opening allows equipment up to 14' by 20' to be installed and serviced through the roof of your building.

STAINLESS STEEL MATERIAL Upgrade to corrosion resistant 304 stainless steel for corrosive environments such as waste water treatment facilities and coastal areas.

DETAILS

MATERIAL

- Aluminum: 11 gauge, mill finish
- Steel: 14 gauge galvaneal, powder coat
- Stainless Steel: Type 304 14 gauge, 2B matte finish

COVER Formed metal cover withstands a live load of 40psf with a max deflection of 1/150 the span

CURB Single wall curb with EZ tab counterflash and mounting flange

INSULATION 1 inch fiberglass in cover, 1 inch polyiso around curb

GASKET Extruded EPDM adhesive backed gasket seal continuous around cover

SPRING/HINGE ASSEMBLY Zinc plated steel tamper-proof hinge contained within spring assembly, includes steel compression spring

HOLD OPEN ARM Zinc plated steel automatic hold open arm with red vinyl grip handle locks cover in open position

LATCH Zinc plated steel latch with exterior and interior turn handles and padlock hasps

FINISHES

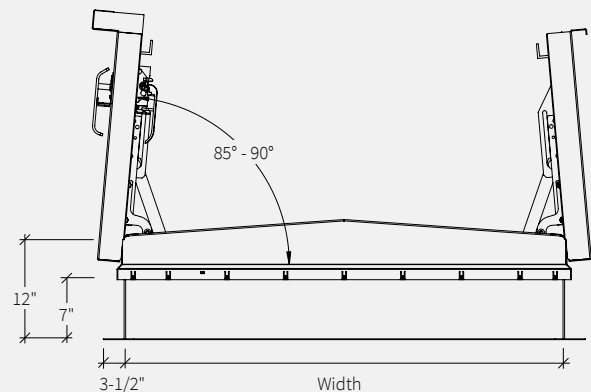

STANDARD MODELS

GALVANIZED STEEL	ALUMINUM	STAINLESS STEEL	SIZE (IN.)	DOOR	CURB
BRHEG48X48S1T	BRHEA48X48S1T	BRHES48X48S1T	48 x 48	Single	Single Wall
BRHEG60X60D1T	BRHEA60X60D1T	BRHES60X60D1T	60 x 60	Double	Single Wall
BRHEG72X72D1T	BRHEA72X72D1T	BRHES72X72D1T	72 x 72	Double	Single Wall
BRHEG60X120D1T	BRHEA60X120D1T	BRHES60X120D1T	60 x 120	Double	Single Wall

Additional sizes and options available, call for more information.