

Hurricane Hatch™

ROOF HATCH

Built to withstand nature's toughest storms, Babcock-Davis' Hurricane Hatch™ is ideal for regions extreme wind conditions. This hatch was tested for wind-uplift, forced entry and air infiltration.

FEATURES

INDUSTRY'S BEST Tested for small and large missile impact - Class IV (TAS 201-94), Air Pressure & Water Penetration (TAS 202-94), and Cyclic Wind Pressure Loading (TAS 203-94).

NEW LARGER SIZES Miami-Dade Approved configurable sizes available up to a maximum opening of 20 ft² area; industry's largest 30" x 96".



DETAILS

MATERIAL

- Aluminum 11 gauge, mill finish
- Steel 14 gauge galvalneal, red oxide powder coat

COVER Formed metal cover with liner, stiffened to withstand a live load of 40psf with a max deflection of 1/150 of the span

CURB Single wall curb with EZ tab counterflash and mounting flange

INSULATION 1 inch polyiso R-6 in curb, 1 inch polystyrene in cover

GASKET Extruded EPDM adhesive backed gasket seal continuous around cover

HOLD OPEN ARM Zinc plated steel automatic hold open arm locks cover in open position

LATCH Zinc plated steel latch with exterior and interior turn handles and padlock hasps.

CERTIFICATION Florida Product Approved and Miami-Dade County

2-POINT LATCH

SPRING / HINGE ASSEMBLY Zinc plated steel tamper-proof hinges contained within spring assembly, includes steel compression springs

SINGLE POINT LATCH

SPRING Gas spring with damper for smooth, controlled lift assistance

HINGE Heavy-duty pintle hinge with stainless steel hinge pin

PULL HANDLE Interior safety pull down handle, yellow powder coat

FINISHES

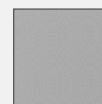

Mill



Red Oxide Powder Coat



High Reflectance White Powder Coat -FP44

STANDARDS SIZES

GALVANIZED STEEL	ALUMINUM	SIZE (IN.)	ACCESS	DOOR	CURB	LATCH
BRHHG30X54S1T	BRHHA30X54S1T	30 x 54	Ship Stair	Single	Single Wall	Single Point
BRHHG30X72S1T	BRHHA30X72S1T	30 x 72	Ship Stair	Single	Single Wall	2-Point
BRHHG30X96S1T	BRHHA30X96S1T	30 x 96	Ship Stair	Single	Single Wall	2-Point
BRHHG36X30S1T	BRHHA36X30S1T	36 x 30	Ladder	Single	Single Wall	Single Point
BRHHG36X36S1T	BRHHA36X36S1T	36 x 36	Ladder	Single	Single Wall	Single Point
BRHHG36X72S1T	BRHHA36X72S1T	36 x 72	Ship Stair	Single	Single Wall	2-Point
BRHHG48X48S1T	BRHHA48X48S1T	48 x 48	Ladder	Single	Single Wall	Single Point

Additional sizes and options available, call for more information.

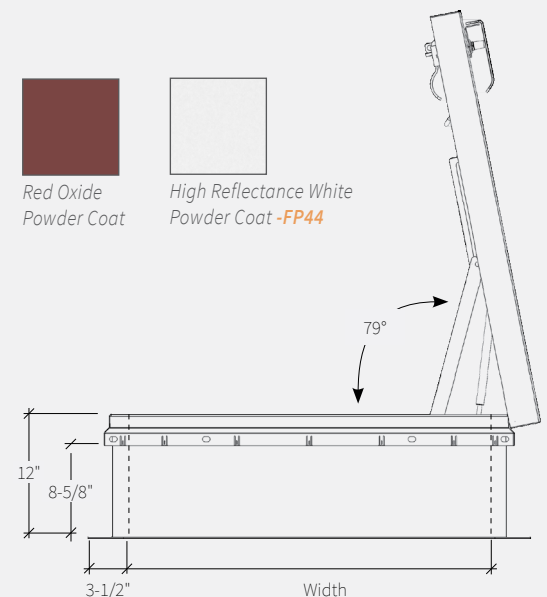

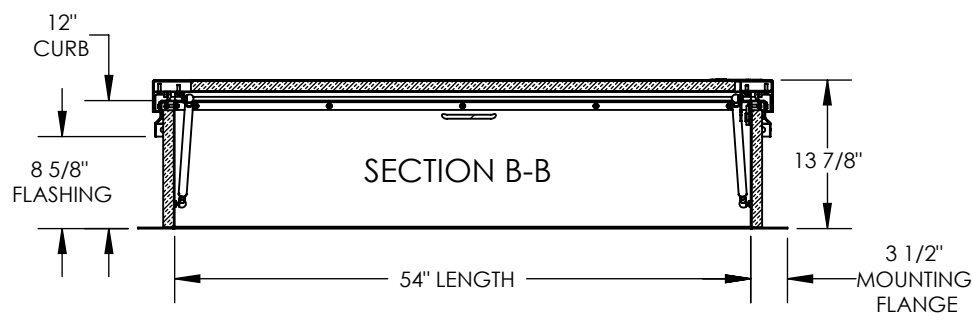
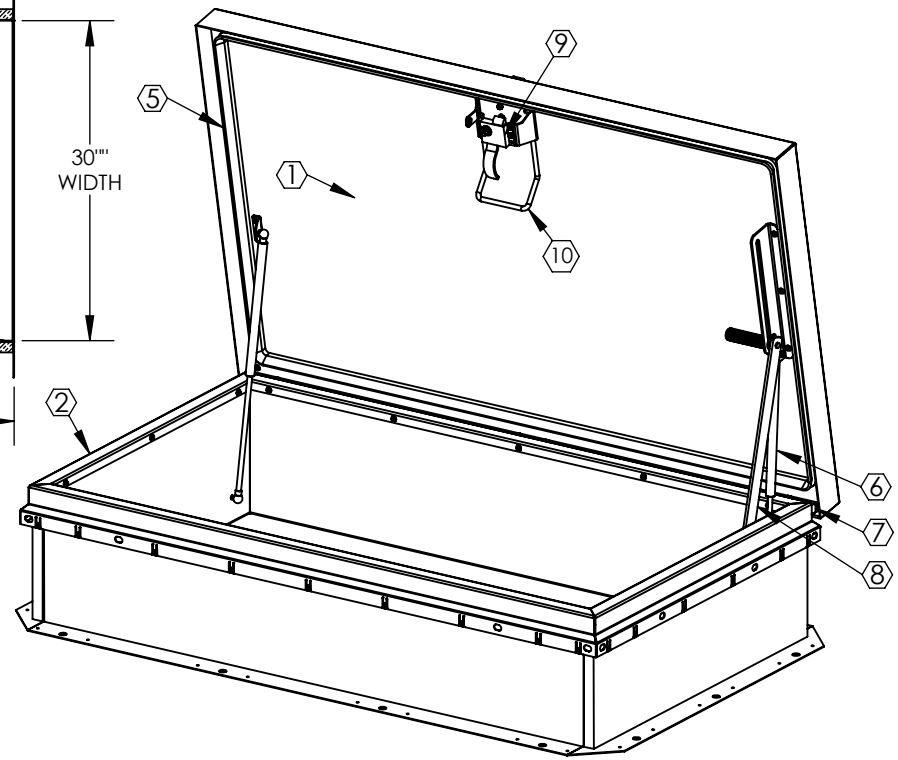
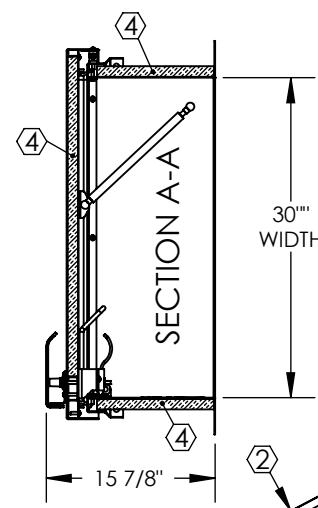
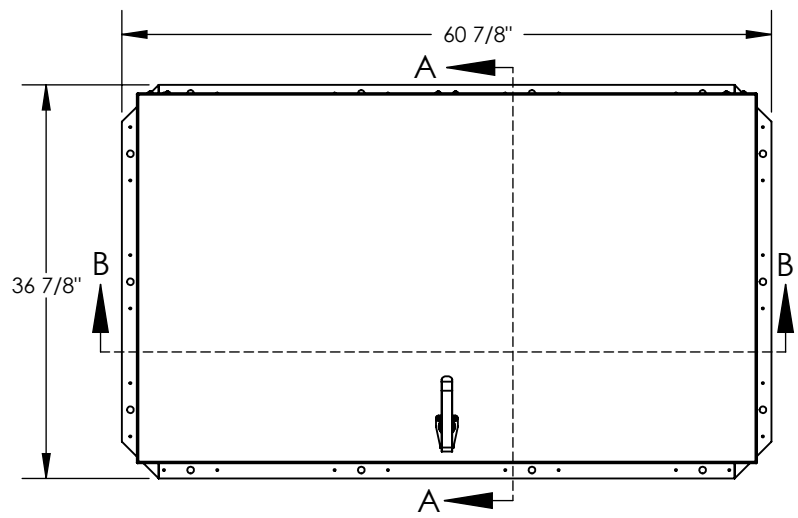

SPECIFICATIONS:

- ① **COVER:** 14GA (.079) GALV STEEL, STIFFENED TO WITHSTAND A LIVE LOAD OF 40PSF WITH A MAX DEFLECTION OF 1/150 OF THE SPAN.
- ② **CURB:** 14GA (.079) GALV STEEL CURB COUNTERFLASH WITH EZ TABS.
- ③ **FINISH:** RED WHITE POWDER COAT
- ④ **INSULATION:** 1" POLYISO R-6 (5.6 LTR) IN CURB, 1" POLYSTYRENE R-4 (3.8 LTR) IN COVER.
- ⑤ **GASKET:** EXTRUDED EPDM RUBBER ADHESIVE BACKED GASKET SEAL COUNTINUOUS AROUND COVER.
- ⑥ **SPRING:** GAS SPRING WITH DAMPER FOR SMOOTH, CONTROLLED, COUNTERBALANCED LIFT ASSISTANCE.
- ⑦ **HINGE:** PINTLE HINGE WITH STAINLESS STEEL HINGE PINS.
- ⑧ **HOLD OPEN ARM:** ZINC PLATED STEEL AUTOMATIC HOLD OPEN ARM LOCKS COVER IN FULLY OPEN POSITION WITH RED VINYL GRIP HANDLE PULL RELEASE.

- ⑨ **LATCH:** ZINC PLATED STEEL SLAM LATCH, HOLDS COVER CLOSED AGAINST WIND UPLIFT, INTERIOR AND EXTERIOR TURN HANDLES WITH PADLOCK HASPS.
- ⑩ **PULL HANDLE:** INTERIOR PULL DOWN HANDLE, SAFETY YELLOW POWDER COAT

NOTES:
 -WHEN INSTALLING ON A PITCHED ROOF UP TO 7:12, THE HINGE SIDE (LENGTH) MUST BE PARALLEL TO THE SLOPE.
 - WIDTH X LENGTH DIMENSIONS ARE MEASURED INSIDE CURB TO INSIDE CURB. THE WIDTH IS HINGE TO LATCH AND LENGTH IS HINGED SIDE.

ROOF HATCH SIZE 30" (WIDTH) x 54" (LENGTH)
CLEAR OPENING 23 1/4" (WIDTH) x 53 1/2" (LENGTH)
ROUGH OPENING 30" (WIDTH) x 54" (LENGTH)

PROPRIETARY AND CONFIDENTIAL: THE INFORMATION CONTAINED IN THIS DRAWING IS THE SOLE PROPERTY OF BABCOCK-DAVIS. ANY REPRODUCTION IN PART OR AS A WHOLE WITHOUT THE WRITTEN PERMISSION OF BABCOCK-DAVIS IS PROHIBITED.

PROJECT:			
ARCHITECT:			
CONTRACTOR:			
QTY:			
PART:			
For more information, contact us at info@bestroofhatches.com or call us at 1-800-431-8651		TITLE: Roof Hatch, Hurricane	
		30x54, Sngl Dr, Galvn Steel, Pwd, Sngl Wall Curb	
NAME	DATE	SIZE	DWG. NO.
RELEASED	IMT	04/01/15	A
WEIGHT: 165 lbs		SHEET 1 OF 2	

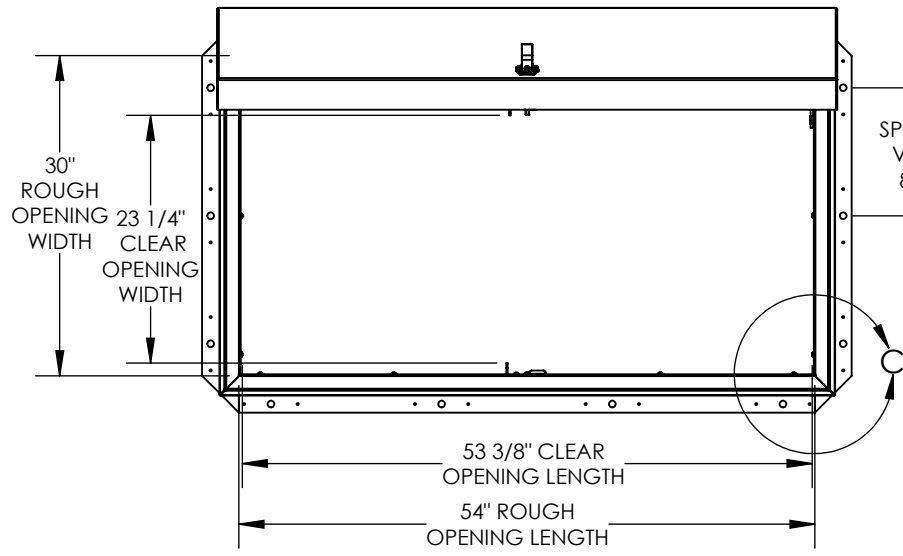

SPACING VARIES 8"-12"

INTERNAL PADLOCK HASP
SLAM LATCH
PULL HANDLE

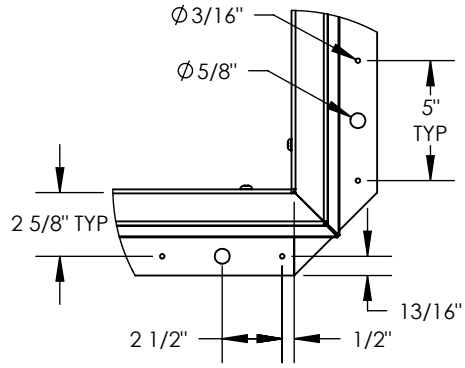
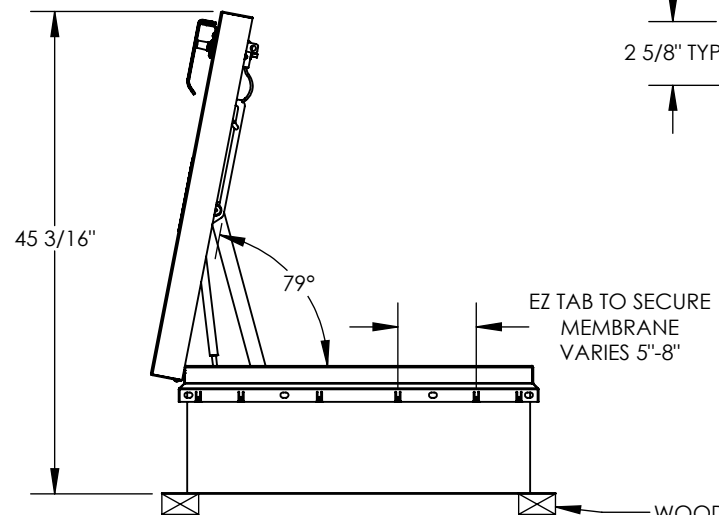
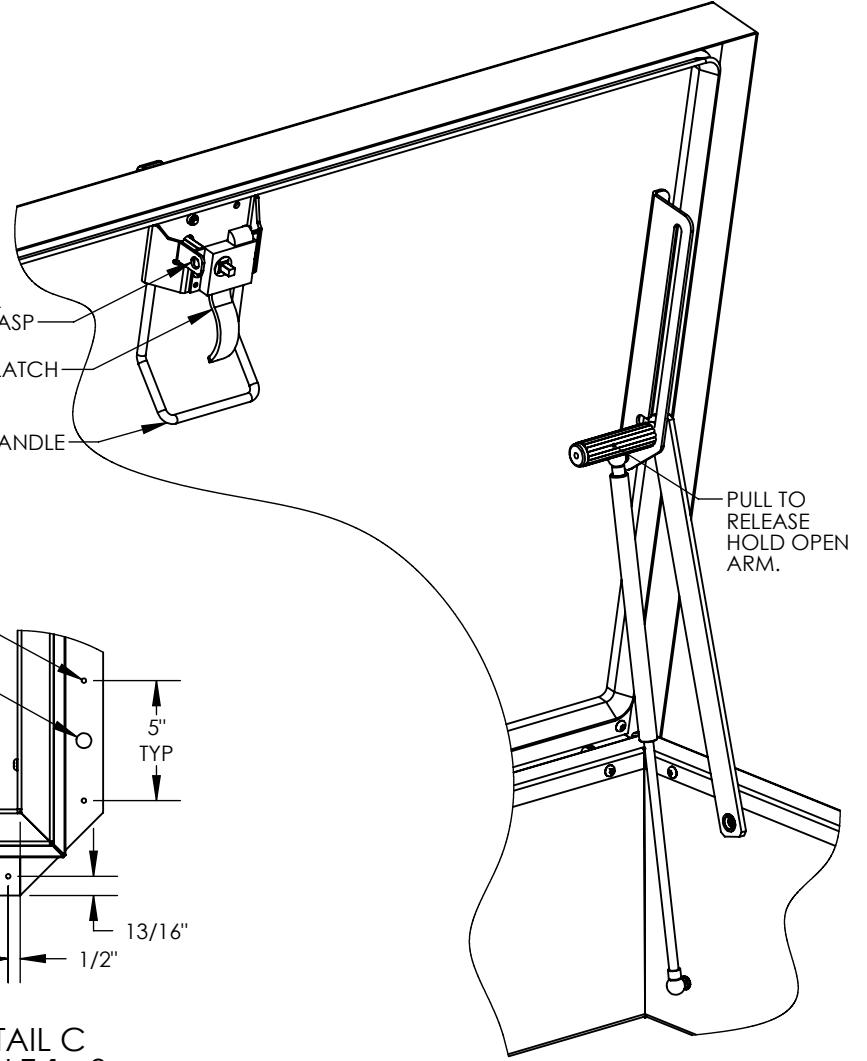

DETAIL C
SCALE 1 : 8

WOOD, CONCRETE, OTHER MATERIAL FOR MOUNTING BY OTHERS (NIC)

 For more information, contact us at info@bestroofhatches.com or call us at 1-800-431-8651				TITLE: Roof Hatch, Hurricane 30x54, Sngl Dr, Galvn Steel, Pwd, Sngl Wall Curb	
	NAME	DATE	SIZE	DWG. NO.	REV
DRAWN	SGS	04/01/15	A		-
RELEASED	IMT	04/01/15	WEIGHT: 165 lbs	SHEET 2 OF 2	

PROPRIETARY AND CONFIDENTIAL: THE INFORMATION CONTAINED IN THIS DRAWING IS THE SOLE PROPERTY OF BABCOCK-DAVIS. ANY REPRODUCTION IN PART OR AS A WHOLE WITHOUT THE WRITTEN PERMISSION OF BABCOCK-DAVIS IS PROHIBITED.