

BEST ROOF HATCHES

GALVANIZED STEEL DOUBLE DOOR ACOUSTICMAX™ 50 SMOKE VENT, MANUAL WINCH WITH ELECTRICAL OPENING MECHANISM

CATEGORY: SMOKE VENTS

SKU: BSVY-D2W

babcockdavis



TOLL FREE PHONE:
1-800-431-8651

EMAIL:
info@bestroofhatches.com

FAX:
1-888-828-6021

www.BestRoofHatches.com

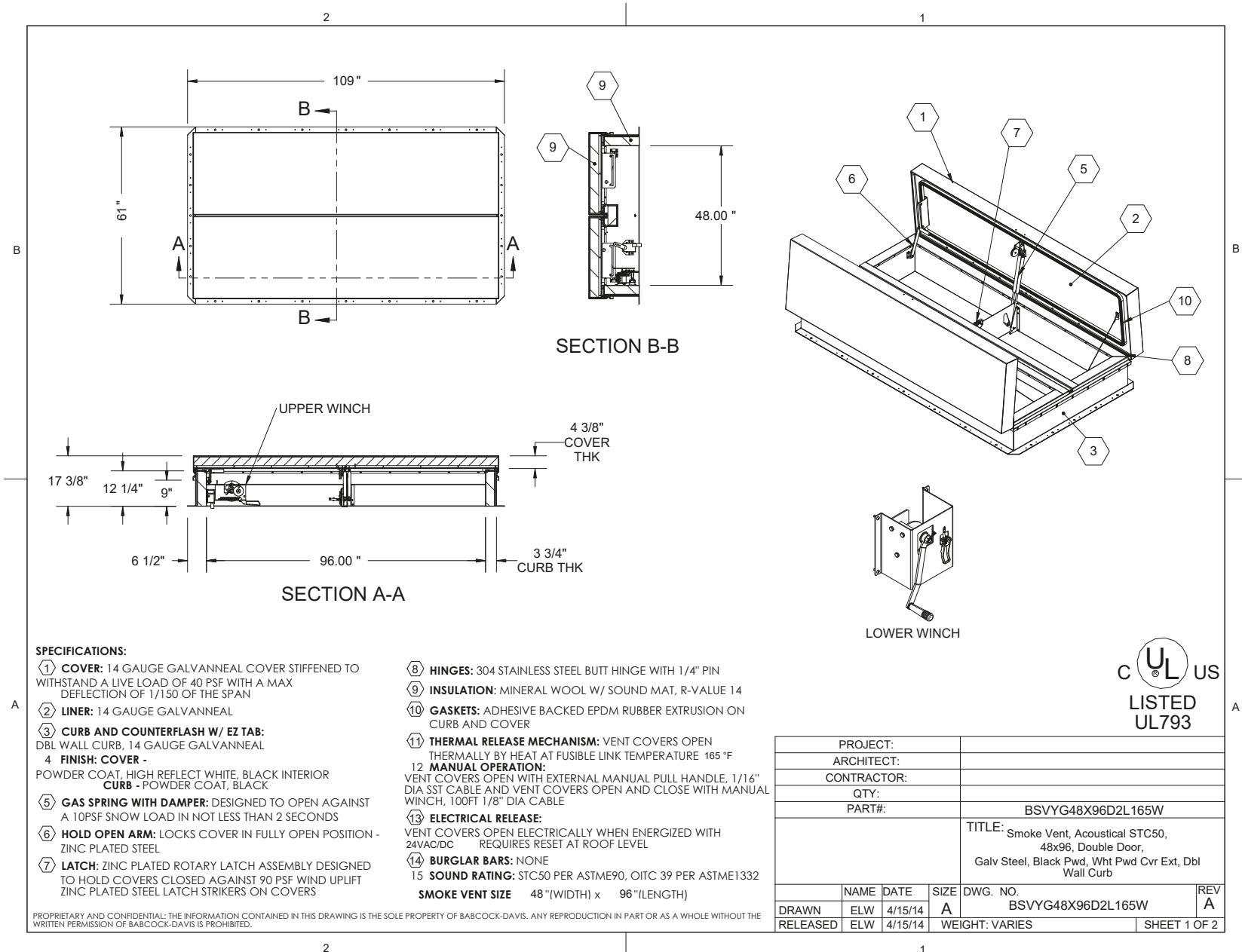

PROJECT:					
ARCHITECT:					
CONTRACTOR:					
QTY:					
PART#:		BSVYG48X96D2L165W			
		TITLE: Smoke Vent, Acoustical STC50, 48x96, Double Door, Galv Steel, Black Pwd, Wht Pwd Cvr Ext, Dbl Wall Curb			
	NAME	DATE	SIZE	DWG. NO.	REV
DRAWN	ELW	4/15/14	A	BSVYG48X96D2L165W	A
RELEASED	ELW	4/15/14	WEIGHT: VARIES	SHEET 1 OF 2	