

NOTES:
SIZE: RB-6'0"X11'0"
 1) 40psf COVER LIVE LOAD RATING
 2) HATCH PAINTED WHITE
 3) MATERIALS:
 14ga GALVANIZED, COVER
 14ga GALVANIZED, CURB
 14ga GALVANIZED, COUNTER FLASHING
 22ga GALVANIZED, COVER LINER

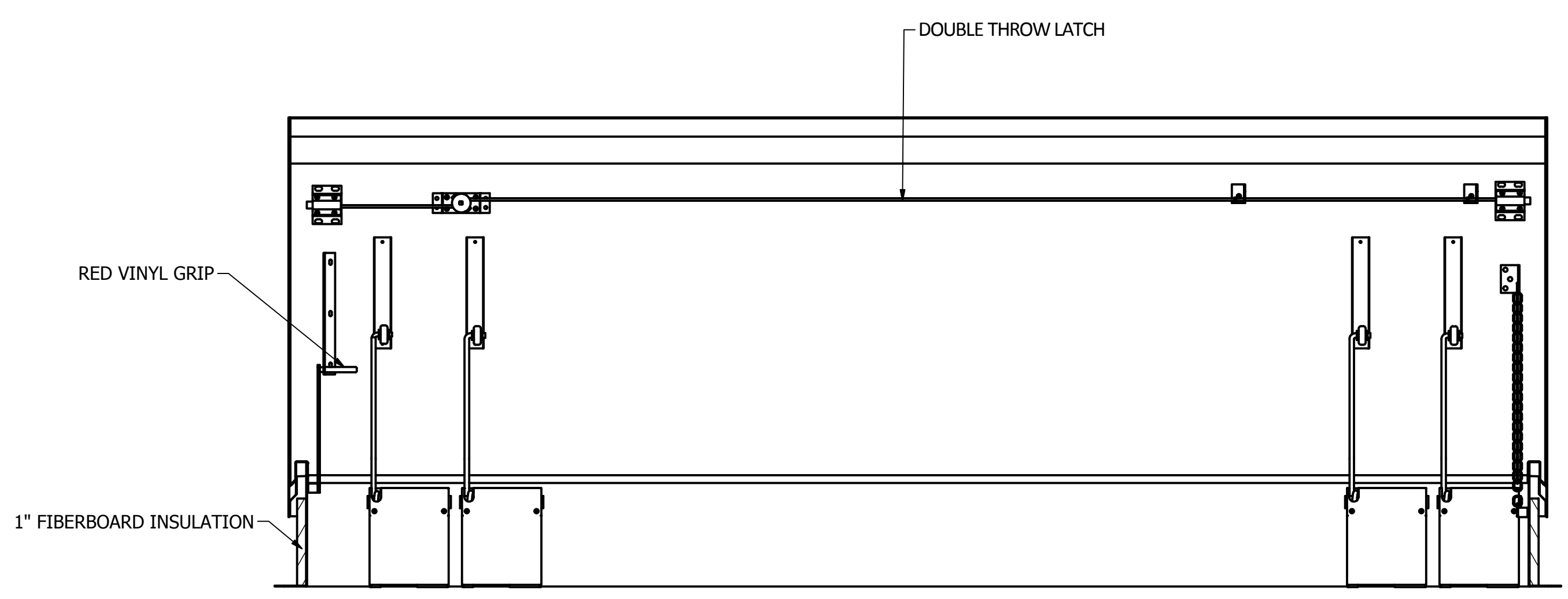
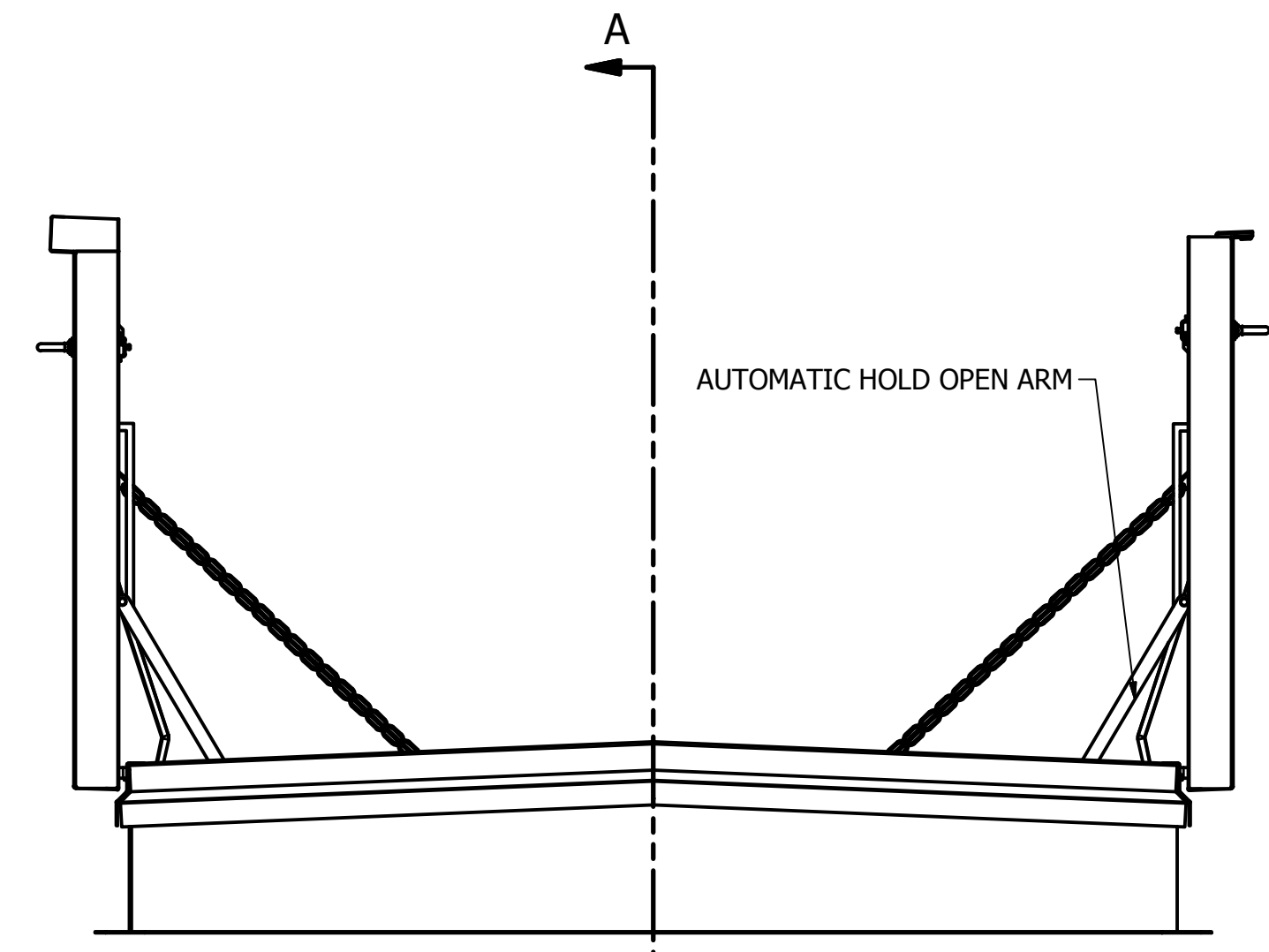

ORDER WILL NOT BE RELEASED FOR FABRICATION UNTIL SIGNED COPY IS RECEIVED.

VERIFICATION AND APPROVAL OF GENERAL ARRANGEMENT AND OVERALL DIMENSIONS FOR THIS DOCUMENT ARE REQUIRED BEFORE THE ORDER IS ENTERED FOR MANUFACTURING.

APPROVAL SIGNATURE _____

TITLE HELD _____

DATE OF APPROVAL _____

BEST ROOF HATCHES For more information, contact us at info@bestroofhatches.com or call us at 1-800-431-8651

DRAWN	CMD	2/25/2015	 for more information, contact us at info@bestroofhatches.com or call us at 1-800-431-8651	
CHECKED	Milcor			
QA	TOLERANCE UNLESS SPECIFIED		TITLE	
MFG	.XXX ± 0.005"		RB-5 DOUBLE LEAF ROOF ASSEMBLY	
APPROVED	.XX ± 0.01"		SIZE	D
	FRACT. ± 1/16"		DWG NO	3501-215-9
	ANGLES ± 1'		SCALE	1" = 1'
			SHEET 1 OF 1	