

**NOTES:**  
**SIZE: RD-6'0"X11'0"**  
 1) 40psf COVER LIVE LOAD RATING  
 2) MILL FINISH  
 3) MATERIALS:  
 .090 ALUMINUM, COVER  
 .090 ALUMINUM, CURB  
 .090 ALUMINUM, COUNTER FLASHING  
 .063 ALUMINUM, COVER LINER

**ORDER WILL NOT BE RELEASED FOR FABRICATION UNTIL SIGNED COPY IS RECEIVED.**

VERIFICATION AND APPROVAL OF GENERAL ARRANGEMENT AND OVERALL DIMENSIONS FOR THIS DOCUMENT ARE REQUIRED BEFORE THE ORDER IS ENTERED FOR MANUFACTURING.

APPROVAL SIGNATURE \_\_\_\_\_

TITLE HELD \_\_\_\_\_

DATE OF APPROVAL \_\_\_\_\_

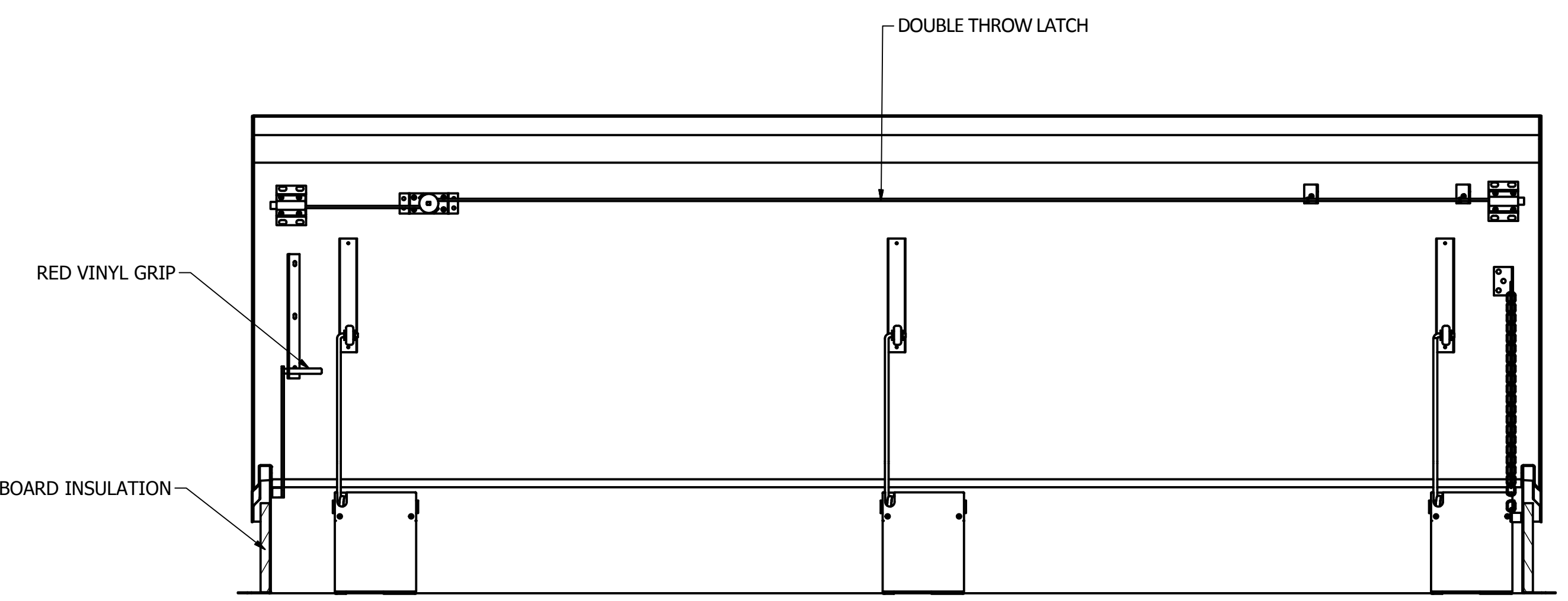
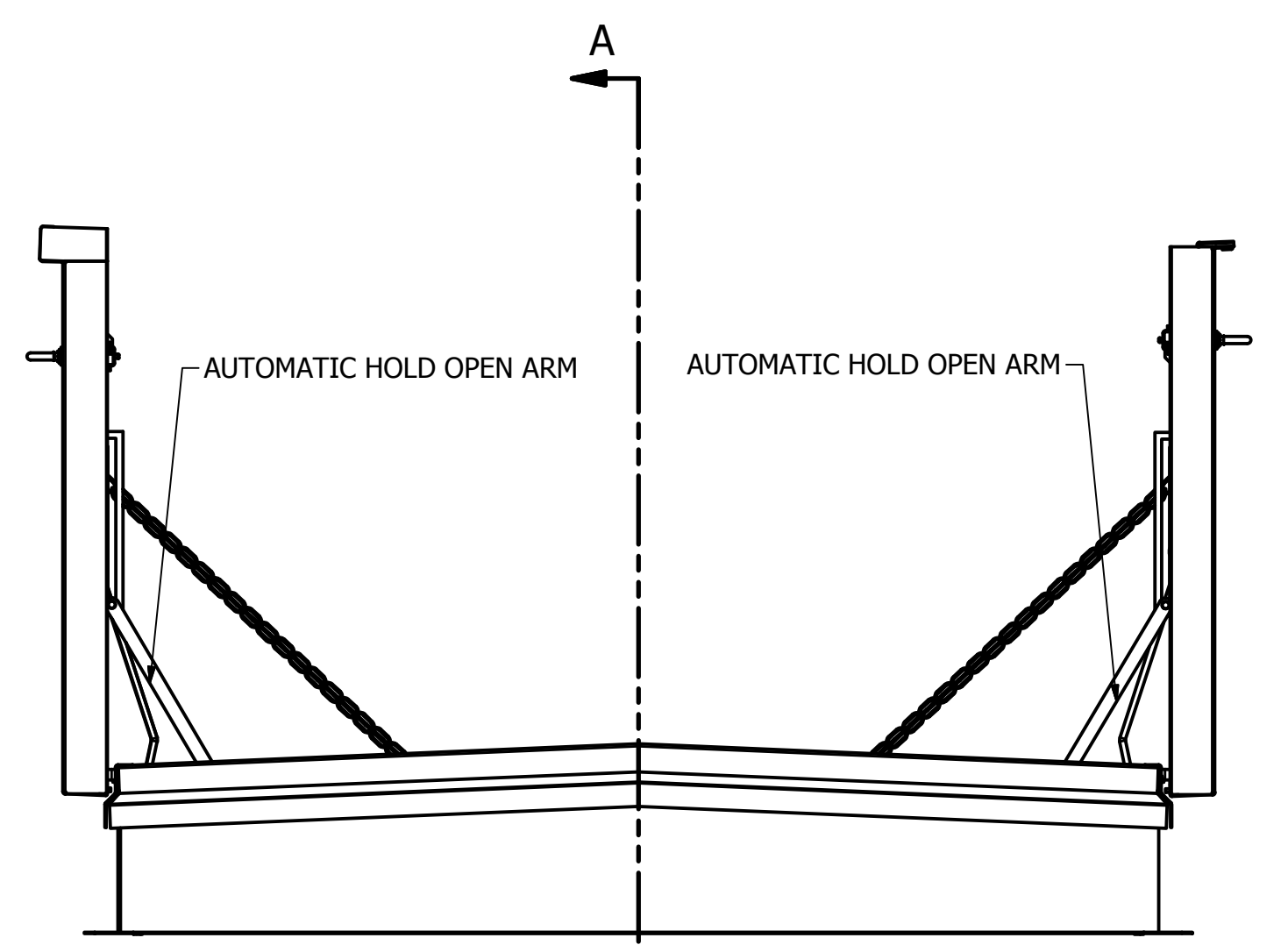

SECTION A-A

**BEST ROOF HATCHES** For more information, contact us at [info@bestroofhatches.com](mailto:info@bestroofhatches.com) or call us at 1-800-431-8651

DRAWN	2/25/2015	 <small>For more information, contact us at info@bestroofhatches.com or call us at 1-800-431-8651</small>
CHECKED	<b>MILCOR</b>	
QA	TOLERANCE UNLESS SPECIFIED	TITLE
MFG	.XXX ± 0.005"	RD-5 DOUBLE LEAF ROOF ASSEMBLY
APPROVED	.XX ± 0.01"	SIZE
	FRACT. ± 1/16"	DWG NO
	ANGLES ± 1'	3501-235-9
		SCALE
		REV
		---
		SHEET 1 OF 1