

NOTES:
 SIZE: RD-8'0"X8'0"
 1) 40psf COVER LIVE LOAD RATING
 2) MILL FINISH
 3) MATERIALS:
 .090 ALUMINUM, COVER
 .090 ALUMINUM, CURB
 .090 ALUMINUM, COUNTER FLASHING
 .063 ALUMINUM, COVER LINER

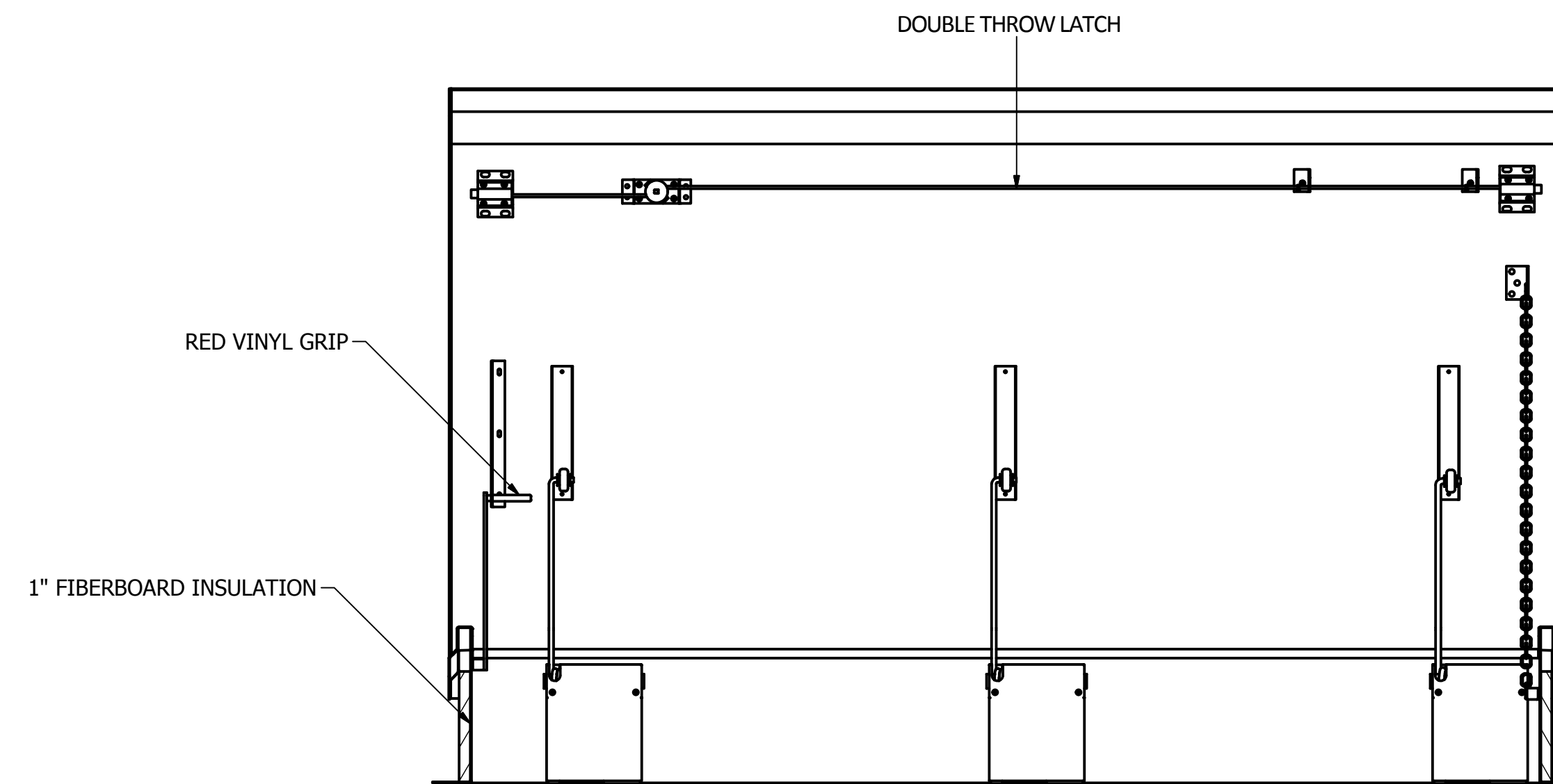
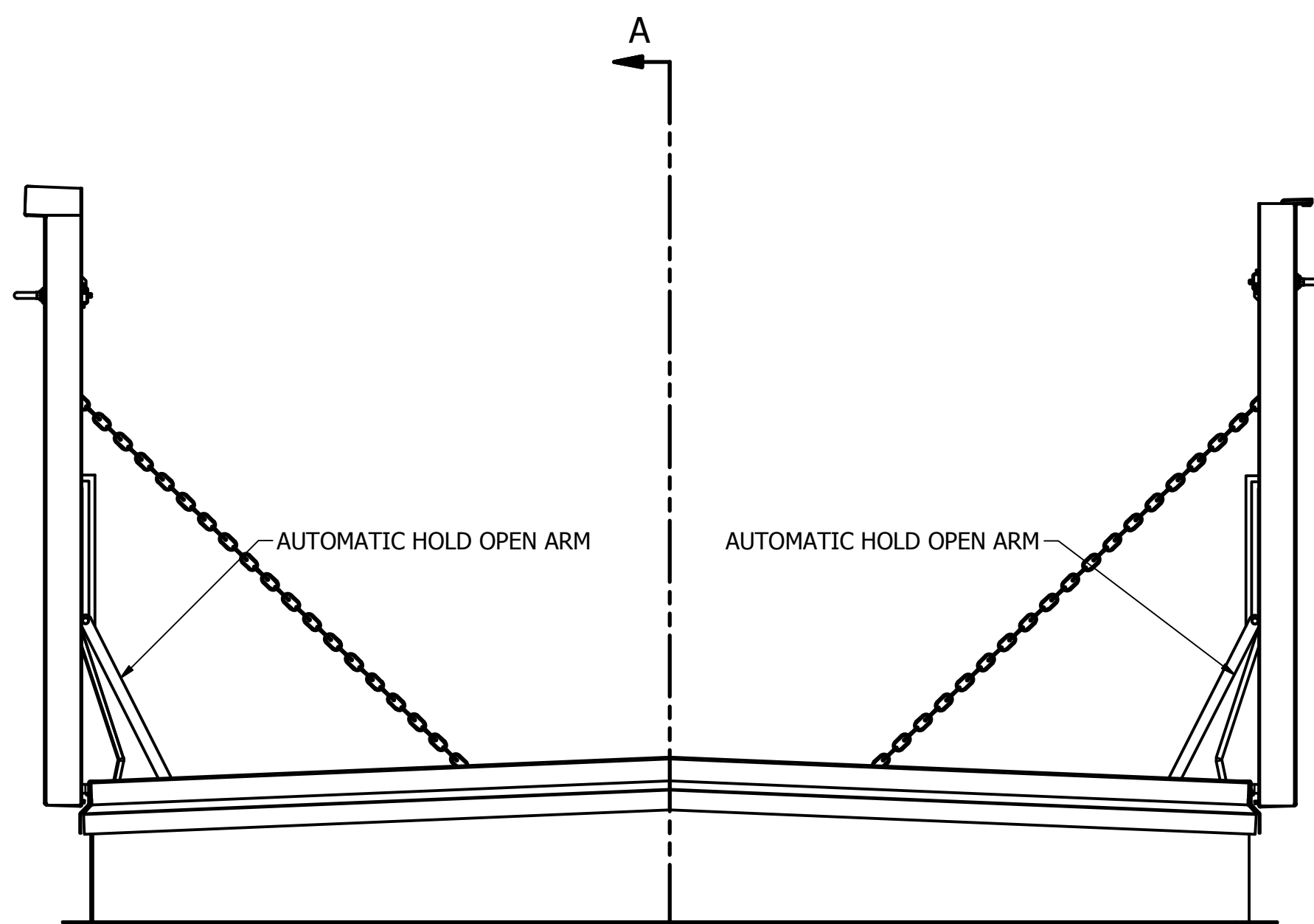

ORDER WILL NOT BE RELEASED FOR FABRICATION UNTIL SIGNED COPY IS RECEIVED.

VERIFICATION AND APPROVAL OF GENERAL ARRANGEMENT AND OVERALL DIMENSIONS FOR THIS DOCUMENT ARE REQUIRED BEFORE THE ORDER IS ENTERED FOR MANUFACTURING.

APPROVAL SIGNATURE _____

TITLE HELD _____

DATE OF APPROVAL _____

BEST ROOF HATCHES For more information, contact us at info@bestroofhatches.com or call us at 1-800-431-8651

DRAWN	CMD	2/25/2015		TITLE	
CHECKED		MILCOR		TOLERANCE UNLESS SPECIFIED	RD-6 DOUBLE LEAF ROOF ASSEMBLY
QA			.XXX ± 0.005"	SIZE	D
MFG			.XX ± 0.01"	DWG NO	3501-238-9
APPROVED			FRACT. ± 1/16"	SCALE	
			ANGLES ± 1'	REV	--
				SHEET 1 OF 1	