

THIS DRAWING IS THE PROPERTY OF THE BILCO COMPANY AND INCORPORATES INFORMATION WHICH IS PROPRIETARY. PUBLICATION AND/OR PUBLIC DISTRIBUTION IN WHOLE OR IN PART IS EXPRESSLY PROHIBITED WITHOUT THE PRIOR WRITTEN CONSENT OF THE BILCO COMPANY. THE INFORMATION CONTAINED HEREIN REMAINS THE PROPERTY OF THE BILCO COMPANY. ALL RIGHTS RESERVED.

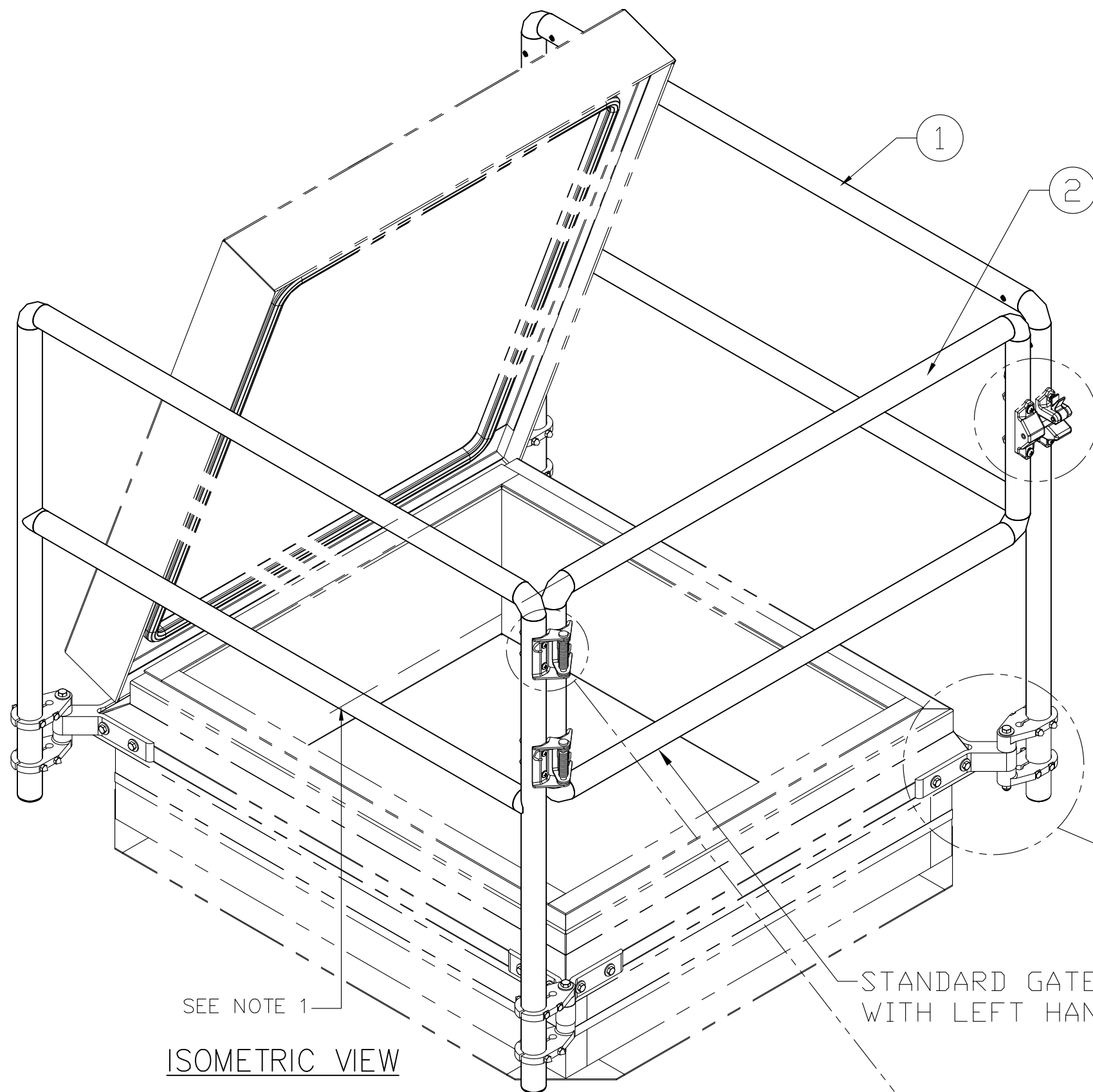

SEE NOTE 1

ISOMETRIC VIEW

STANDARD GATE LOCATION WITH LEFT HAND SWING

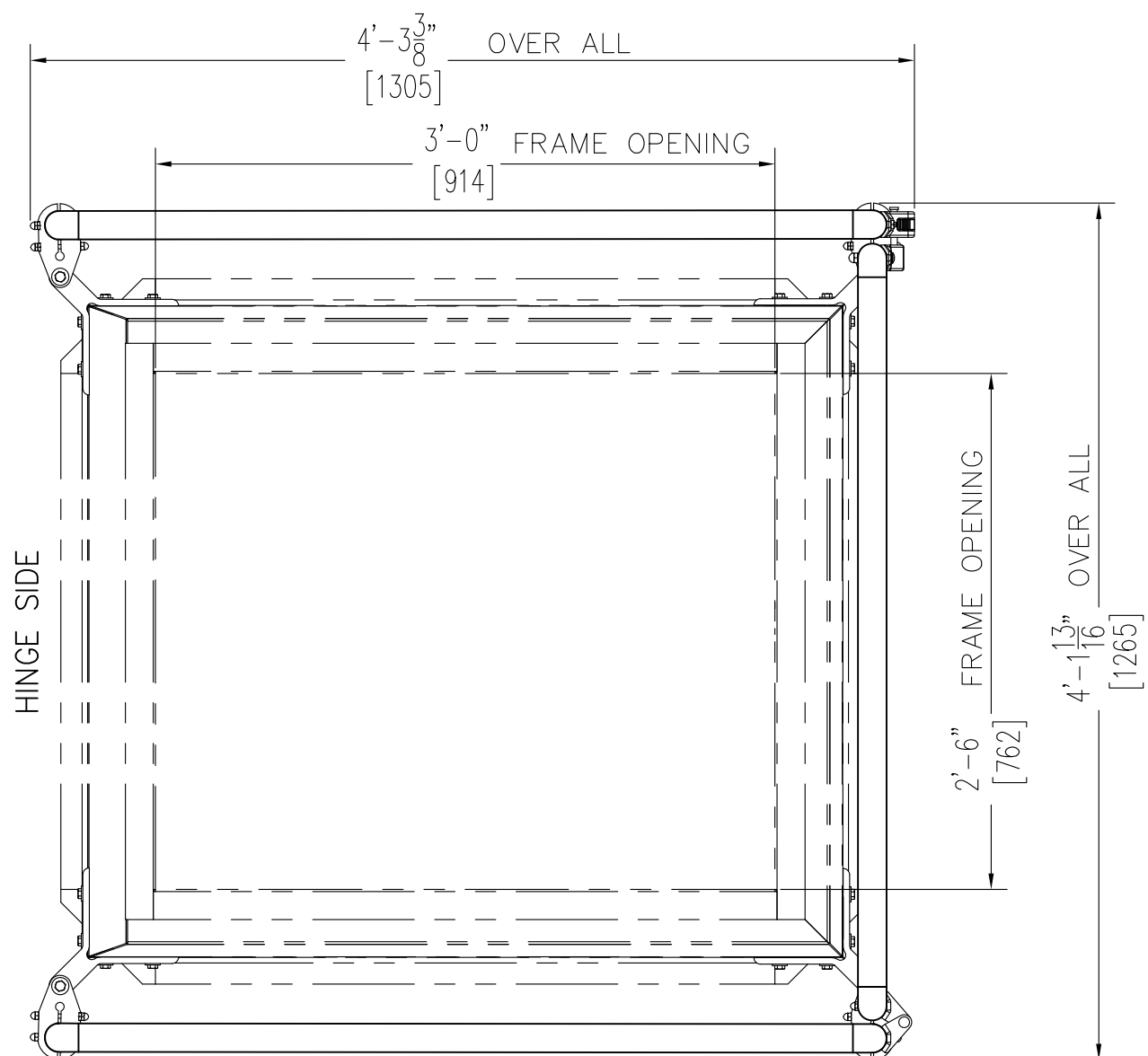
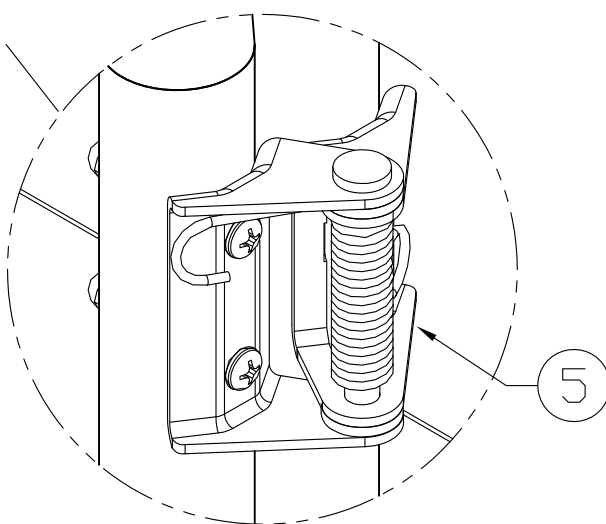
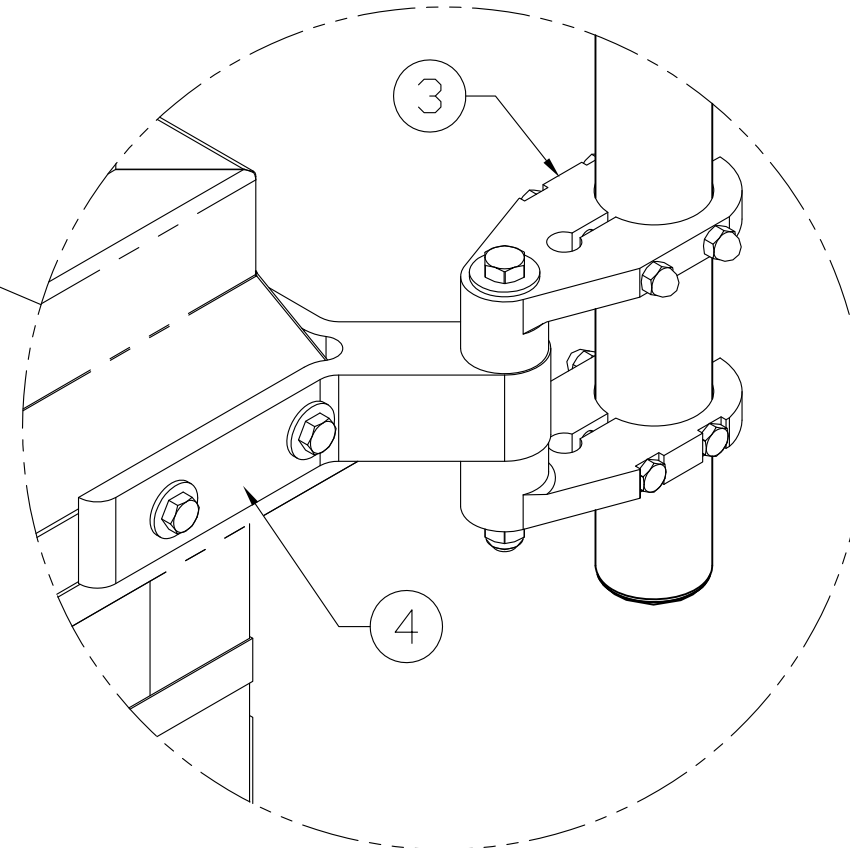
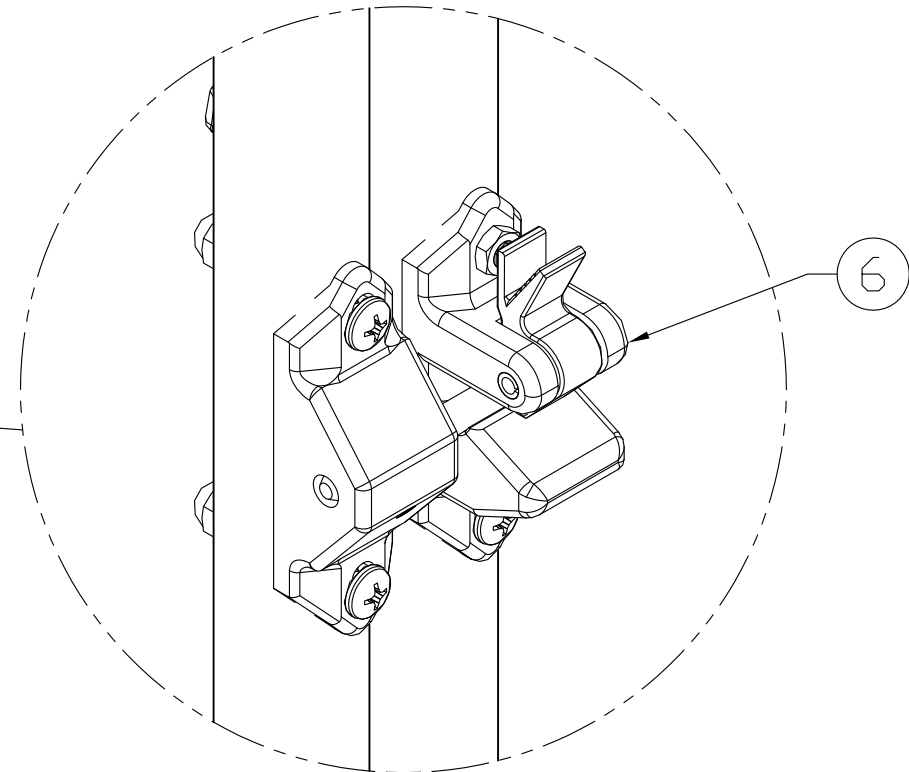

PLAN VIEW  
SHOWN WITHOUT COVER

SPECIFICATIONS

1. 1 1/4" SCHEDULE 40 PIPE IN 6061 T6 ALUMINUM ALLOY RAILS
2. SELF CLOSING GATE
3. ALUMINUM POST SUPPORTS
4. CORNER BRACKETS
5. STAINLESS STEEL SPRING HINGES
6. CAST ALUMINUM GATE LATCH W/ STAINLESS STEEL PIN

NOTES:

1. TOP OF RAIL TO BE SET 42" ABOVE THE ROOF SURFACE OR DECK
2. LEFT HAND GATE SHOWN
3. ALL FASTENERS ARE STAINLESS STEEL
4. ALL PARTS AND FASTENERS ARE INCLUDED IN PACKAGE. CAPFLASHING MUST BE STRUCTURALLY SOUND TO SUPPORT ASSEMBLY
5. POWDER COAT FINISH IN RAL 1018, SAFETY YELLOW

ROOF SCUTTLE NOT INCLUDED

CUSTOMER:

P.O. N°:

JOB:

SALES REP:

Manufacturers of Doors for Special Services  
**Bilco**® THE BILCO COMPANY  
 New Haven, Connecticut 06505

BIL-GUARD®2.0 – HATCH RAIL SYSTEM FOR SINGLE LEAF THERMALLY BROKEN ROOF SCUTTLE WITH 3" STANDARD CAP FLASHING

QTY	TYPE	SIZE	WIDTH x LENGTH
□	RL2-STB	SIZE 3'-0" x 2'-6"	[914mm x 762mm] HINGE SIDE

WEB SITE: [www.bilco.com](http://www.bilco.com)



For more information, contact us at [info@bestroofhatches.com](mailto:info@bestroofhatches.com) or call us at 1-800-431-8651